

Permit No. _____

Fee Paid: _____

Receipt No. _____

LAKE TOWNSHIP, STARK COUNTY, OHIO

APPLICATION FOR A PERMIT TO EXCAVATE WITHIN TOWNSHIP PUBLIC HIGHWAYS, INCLUDING RIGHT-OF-WAYS, TO THE BOARD OF TRUSTEES:

Application is hereby made by:

Name: _____

Address: _____

Phone: _____

Date: _____

PERMIT TO EXCAVATE:

- Driveway
- Road Cut

- Curb Cut
- Road Right of Way

- All Roads to Be Bored
When Possible**

LOCATION:

Name of Road: _____

From: _____ To: _____

The purpose of the excavation is: _____

Diameter of Pipe/Conduit (plus linear ft. of excavation if pipe/conduit exceeds 18"): _____

Work will commence on or about _____ and will be completed on or about _____. If this application is approved and a permit is issued, the Applicant agrees to comply with all the terms, conditions and restrictions printed or written on the back of this sheet and/or attached hereto as "addendum," as amended or supplemented in accordance with the detailed plans submitted and attached to this application.

Signed _____
(Contractor doing work)

Signed _____
(Applicant)

Name & Title (please print)

Name & Title (please print)

PERMIT

The above application is hereby:

_____ Approved and permission is granted to do the work covered in the application, which work shall be done in strict conformity with the terms, conditions, and restrictions of the permit as contained on the reverse hereto or attached hereto.

_____ Disapproved and excavation is prohibited for the above work under penalty of law.

NOTE: WORK MAY NOT BE COMMENCED UNTIL A BOND IS POSTED AND APPROVED BY FISCAL OFFICER

LAKE TOWNSHIP BOARD OF TRUSTEES

DATED: _____ 20____

Bond in the form of _____ in the amount of \$_____ is hereby deposited with the Fiscal Officer of the Board of Lake Township Trustees to be held and used if necessary, as provided in the terms, conditions and restrictions hereof.

DATED: _____, 20____

Fiscal Officer

WHITE – Office Copy

CANARY – Applicant's Copy

PINK – Contractor's Copy

Board of Lake Township Trustees ♦12360 Market Avenue North, Hartville, Ohio 44632♦

330.877.9479 (Phone)♦330.877.4179 (Fax)

**TERMS, CONDITIONS AND RESTRICTIONS THAT APPLY
TO THE ISSUANCE OF A PERMIT FOR EXCAVATING
IN ANY LAKE TOWNSHIP PUBLIC HIGHWAY**

NOTE: WHEN POSSIBLE — ALL ROADS TO BE BORED

The foregoing permit is issued under the authority of the Board of Lake Township Trustees, by Resolution No. 03-035 & 03-199 and amended under Resolution No. 16-094, adopted pursuant to Ohio Revised Code Section 5571.16. That Resolution requires anyone who desires to make any excavation in any Lake Township public highway (which for the purposes of these conditions is defined as the road surface, its sub-surface, and right-of-way) to obtain a permit for each such excavation prior to the commencement of the excavation. Any work performed at such excavation shall be done in accordance with Ohio law and the conditions contained in this permit. These conditions are binding upon the Applicant as herein defined. Once the permit application is submitted to the Township Clerk, the fee paid and the required bond posted, work may commence upon approval of and under the supervision of the Road Superintendent of Lake Township. For the purposes of these conditions, the term "Applicant" includes any contractor or employee performing any work related to this permit, and all of their heirs, executors, administrators, successors, and assigns and any agents of any such individuals or entities.

1. The Applicant for a permit shall submit detailed plans for each contemplated excavation indicating the location, size, type, and dimensions at least forty-eight hours prior to the date on which excavation will begin if a permit is issued. The fee for each road excavation permit, shall be based upon the diameter of the pipe/conduit, and shall be as follows:

One (1) inch or smaller	\$ 25.00
Greater than one (1) inch up to four (4) inches	\$ 50.00
Greater than four (4) inches up to eight (8) inches	\$100.00
Greater than eight (8) inches up to eighteen (18) inches	\$200.00
Greater than eighteen (18) inches	\$200.00 plus \$10.00 per linear foot of excavation
Any single application to install six (6) or more poles for electric service or telecommunications service or to install a pole associated with underground electric or telecommunication service	\$ 50.00

The Applicant shall also deposit a bond as set forth in number 2, below.”

2. The Applicant shall deposit with the Clerk of Lake Township, as a cash deposit (in the form of a check) or a surety bond to insure adherence to these terms, in the sum of Fifteen Hundred Dollars (\$1,500.00) or 15% of the contract amount for the excavation, whichever is greater. Said surety or sureties shall be satisfactory to the Board of Lake Township Trustees and any bond shall be payable to the Board of Lake Township Trustees. Said deposit or bond shall be conditioned upon the restoration of the public highway to the condition prevailing at the time immediately prior to the excavation or to the condition herein specified if work is performed on an emergency basis. Said deposit shall be refunded or the bond shall be released within sixty (60) days after the restoration of the public highway and upon recommendation of the Road Superintendent and the approval thereof by resolution of the Board of Lake Township Trustees finding that the public highway has been restored to the condition prevailing at the time of the issuance of the permit or at the time of the commencement of the excavation in the case of an emergency as hereinafter provided. Should the person or business to whom a permit has been issued fail to restore said public highway as provided herein within ninety (90) days of the issuance of the permit or the opening of the excavation, whichever date is later, then the deposit or bond shall be forfeited to the Board of Lake Township Trustees and the said Board shall take legal action to enforce said bond and restore the affected public highway, all at Applicant's cost and expense, to all of which in such event, Applicant agrees to pay, including court costs, and the Board's attorneys fees and related expenses.

3. The Applicant for any permit issued hereunder shall be responsible for obtaining all other permits required for construction and notify applicable utilities of the pending excavation, and for spotting, marking, and if necessary, having utilities located in the area of excavation relocated at its sole cost prior to commencing excavation. The Applicant shall be responsible for any damage to the public highway and any associated structures and shall make repairs as deemed necessary by and to the satisfaction of the Board of Lake Township Trustees. The Applicant shall also be responsible for the installation and maintenance of adequate signs and warning devices to inform and protect the public. The Applicant shall be responsible for the maintenance of traffic throughout the construction period and shall comply with the requirements of the Ohio MANUAL OF UNIFORM TRAFFIC CONTROL DEVICES ("MUTCD") at all times until the work is completed.
4. The Applicant shall excavate, backfill, refill and resurface any public highway covered by the permit to be issued to the Applicant in accordance with these permit conditions and the directions and specifications as provided by the Board of Lake Township Trustees with the advice and consultation of the Road Superintendent of Lake Township. All excavations and materials including backfilling, refilling and resurfacing and the method of compaction shall be performed and completed in a manner satisfactory to the Board of Lake Township Trustees.
5. The length of open trenches if any constructed during excavation shall be kept to a minimum and shall be protected by signs, barricade and lights as necessary and in conformance with the requirements of the Ohio MUTCD.
6. The function of existing traffic control devices shall be retained at all times during excavation and before completion. Existing signs that must be relocated laterally shall be placed in accordance with the Ohio MUTCD and such signs shall not be moved without the approval of the Board of Township Trustees or the Stark County Engineer as the case may be. The Applicant shall restore relocated traffic and street signs to the positions and conditions that existed prior to construction and shall replace all paving markings in accordance with Ohio law and the Ohio MUTCD.
7. No "off the road" equipment with steel tires, treads, cleats, stabilizing pads or similar equipment will be permitted on public highway pavement without the use of proper planking as approved by the Board of Lake Township Trustees or its Road Superintendent.
8. The Applicant shall at all times provide and maintain suitable driveways to and from abutting properties so as to allow ingress and egress to and from such properties. The Applicant shall be responsible for any and all damages to any abutting property owner or any interference to their activities including the business activities of any such abutting property owner.
9. The Applicant hereby agrees to indemnify and save Lake Township, the Board of Lake Township Trustees, including its individual Trustees and its officers, agents, and employees as well as its successors and assigns absolutely free and harmless from any and all claims for damages to persons or property which might arise or be connected in any way with any excavation to be performed by the Applicant as a result of the issuance of any permit for excavation in a public highway within this jurisdiction.
10. The Applicant shall complete any sub-road excavation by BORE method rather than open-cut unless specifically authorized otherwise by the Board of Lake Township Trustees through its Road Superintendent. Drainage from the road surface and road right-of-way at the site of excavation will be maintained at all items during excavation.
11. The Applicant shall be responsible for restoring the public highway to as good condition as originally found, and repair and replace any and all roadway structures without cost to the Board of Lake Township Trustees and to its reasonable satisfaction. Restoration of all areas outside of the paved area will be made to the satisfaction of the Board of Lake Township Trustees and shall be in accordance with State of Ohio Department of Transportation Construction & Materials Specifications Manual Item #659. All debris from the construction site including any excess excavation materials shall be removed from the site of the excavation and properly and lawfully disposed of at the cost of the Applicant. Neither dumpsters nor any other types of obstructions can be placed in the public highway.
12. The cash deposit or surety bond deposited with the Board of Lake Township Trustees for this permit shall be held by the Clerk until such time as the excavation is adequately restored to the satisfaction of the Board and a sufficient period of time has passed to allow for adequate ground settling as determined by the Board of Lake Township Trustees. Moreover, the cash deposit or surety bond shall be held to insure satisfactory compliance with all terms and conditions of this permit by the Applicant. The cash deposit shall then be returned to the contractor or the surety bond, if provided, shall then be released, both without interest, upon satisfactory completion of the excavation to the satisfaction of the Board of Lake Township Trustees and full compliance with the conditions of the excavation permit and Ohio law. In the event that the conditions of the permit are not promptly, fully and completely adhered to by the Applicant, the Board of Township Trustees may direct its Clerk to retain said deposit and/or deduct from said deposit

any sum deemed necessary to restore the excavation site or to fulfill the terms, conditions and restrictions as to the issuance of any excavation permit. The retention or deduction of any such damages from the deposit or bond, however, shall not be construed to be liquidated damages, and the Applicant shall be responsible for any and all damages that might proximately flow from any failure to comply with the terms of this permit or Ohio law.

13. Before commencement of the excavation, the Applicant shall notify the fire and police departments, the school system, and the post office located in and/or having jurisdiction over the area where the excavation is to occur of the excavation work, the date of commencement and the completion of said work.
14. If an emergency occurs, such as a burst or leaking pipe, or similar problem which requires immediate action to protect the public health, safety, and welfare, a contractor may proceed with a road opening if the contractor adheres to all terms and conditions hereof, notifies the Lake Township Road Superintendent upon the commencement of the work, and provides a completed application and bond as required herein as soon as possible thereafter but not later than two (2) days after an excavation has been commenced.

NOTICE:

No person shall make an excavation in any township highway in violation of any resolution adopted pursuant to Section 5571.16 of the Ohio Revised Code.

SEE DETAILS FOR TYPICAL PAVEMENT REPLACEMENT SECTIONS

DWG.NO. 1A

Made Part of Lake Township Road Open Permit Terms, Conditions and Restrictions

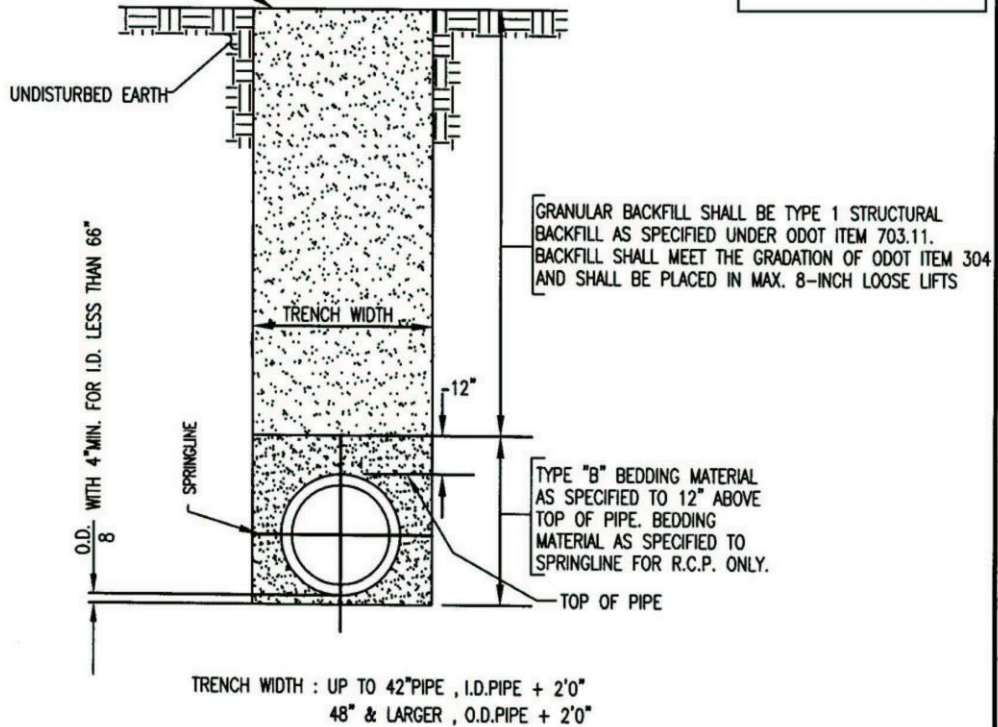

NOTES:

1. THIS TRENCH BACKFILL DETAIL APPLIES TO AREAS UNDER EXISTING PAVEMENT.
 2. STARK COUNTY BEDDING CLASSIFICATION TYPE B MEETS OR EXCEEDS ASTM D-2321 CLASS 1 BEDDING FOR FLEXIBLE PIPING, AND ASTM C-12, CLASS B BEDDING FOR RIGID PIPING.
 3. BACKFILL SHALL BE COMPACTED TO THE REQUIREMENTS OF ITEM 1 IN THE SPECIFICATIONS.
 4. COMPACTION OF THE BACKFILL SHALL BE ACHIEVED THROUGH THE USE OF A MECHANICAL VIBRATORY ROLLER.
 5. COMPACTION TESTING OF THE BACKFILL SHALL BE PROVIDED, DIRECTED AND COORDINATED BY THE OWNER. INTERVALS OF TESTING SHALL BE AT THE TOTAL DISCRETION OF THE OWNER AND MAY BE CHANGED AT ANY TIME.
- IF A TEST DOES NOT PASS, THE CONTRACTOR SHALL REMOVE THE DEFECTIVE BACKFILL, REDO THE WORK AND THE AREA WILL BE RETESTED. THE CONTRACTOR SHALL BE AWARE OF THE LEVEL OF COMPACTION REQUIRED.
- IF THE WORK IS SUSPECT TO BE DEFECTIVE BY THE OWNER, THE WORK SHALL BE RETESTED.
- THE WATER CONTENT OF THE BACKFILL MATERIAL SHALL ALSO BE TESTED AND RECORDED FOR EACH TEST COMPLETED. THE CONTRACTOR WILL BE ALLOWED TO ADD WATER TO THE BACKFILL MATERIAL IN ORDER TO OBTAIN THE OPTIMUM WATER CONTENT. HOWEVER, THE CONTRACTOR WILL NOT BE ALLOWED TO UTILIZE THE ADDITION OF WATER AS A MEANS OF COMPACTION. FURTHERMORE, SHOULD THE BACKFILL MATERIAL BE FOUND TO HAVE WATER CONTENT RATIOS WHICH IN THE OPINION OF THE ENGINEER OR THE OWNER PREVENTS THE APPROPRIATE COMPACTION OF THE TRENCH, THE CONTRACTOR SHALL REMOVE ALL DEFECTIVE MATERIAL AND UNDERTAKE THE NECESSARY CORRECTIVE WORK.

NO SCALE

APR'D 08/02

REVISION	DATE	BY
ODOT ITEM 703.11	9/02	BGD

STARK COUNTY SANITARY ENGINEERING DEPT.	
DETAIL DWG.NO.	1A
ITEM NO.	6
TRENCH BACKFILL UNDER EXISTING PAVEMENT DETAIL	

DWG.NO. 18

Made Part of Lake
Township Road
Open Permit Terms,
Conditions and
Restrictions

PAYMENT LIMIT FOR ALL PAVEMENT SHALL BE
TRENCH WIDTH + 2'-0"

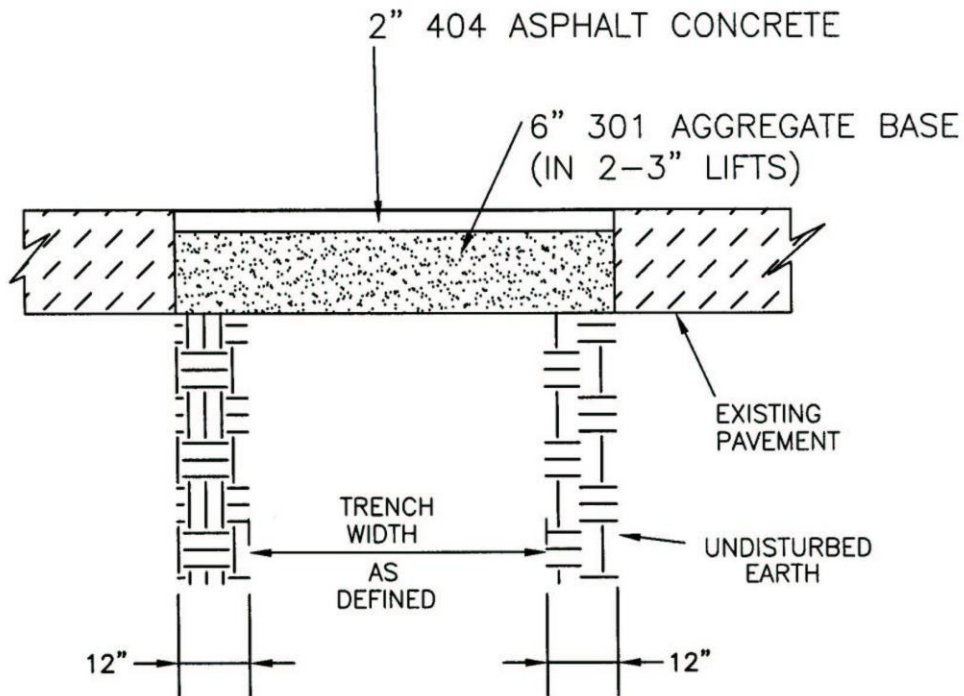

GENERAL PAVEMENT NOTE:

WHERE EDGES OF REPLACED SECTION EXTENDS WITHIN 2'-0" OF ROADWAY EDGE, PAVEMENT IS TO BE REPLACED TO ROADWAY EDGE AT NO ADDITIONAL COST.

NO SCALE

APR'D 08/02

REVISION	DATE	BY
REVISED PAVEMENT MAT.	08/02	BGD

STARK COUNTY
SANITARY ENGINEERING DEPT.

DETAIL DWG.NO. 18
ITEM NO. 21C

ASPHALT CONCRETE
SURFACE COURSE
ASPHALT BASE COURSE